

Introduction to Same Band Combining of UMTS & GSM



Table of Contents

1. Introduction	2
2. Non-Filter Based Combining Options	2
3. Type 1 Combiners	2
4. Type 2 Combiners	3
5. Overview of Active & Passive Combiners	3
6. Same Band Combining of GSM & UMTS	3
7. Active Type 1 Combiners	4
8. Passive Type 1 Combiners	6
9. Active Type 2 Combiners	8
10. Passive Type 2 Combiners	10
11. Passive Type 3 Combiners	12
12. References	14

Figures

Figure 1 Sandwhich Arrangement (source ECC reports [2], [3])	4
Figure 2 Typical Spectrum of Active Type 1 Combiner	4
Figure 3 Active Type 1 Combiner - Typical System Block Diagram	5
Figure 4 Typical Spectrum of Passive Type 1 Combiner	6
Figure 5 Passive Type 1 Combiner - System Block Diagram	7
Figure 6 Typical Spectrum of Active Type 2 Combiner (at antenna ports)	8
Figure 7 Active Type 2 Typical System Block Diagram	9
Figure 8 Typical Spectrum of Passive Type 2 Combiner (at the antenna port)	10
Figure 9 Passive Type 2 Combiner - Typical System Block Diagram	11
Figure 10 Typical Spectrum of Passive Type 3 Combiner (at both antenna ports)	12
Figure 11 Passive Type 3 Combiner System Block Diagram	13

1. Introduction:

Same Band Combiners (SBC) are RF modules designed for combining cellular base stations with the same or different technologies in a similar frequency band to a common antenna.

Examples of technologies which can be combined using this technique include:

- GSM + GSM
- UMTS + UMTS
- GSM + UMTS
- GSM + LTE,
- UMTS + LTE
- TDMA + GSM
- IS95 CDMA + 1X/3X EVDO etc.

The advantage of using a SBC is that infrastructure such as feeders, tower mounted amplifiers and antennas can be shared by multiple base stations or node-Bs. This means less equipment is required per sector with the benefits of lower operational & capital expenditure (opex/capex) as well as more efficient use of tower space.

2. Non-Filter Based Combining Options:

Note this application note has focused on filter-based methods of combining cellular technologies. There are several alternatives which are not discussed here further:

- a) Hybrid combining:
This is generally lower cost than filter based combining however suffers from the disadvantage that there is approximately 3.5dB insertion loss in both the uplink & downlink. Usually requires a low PIM load for the isolated port.
- b) Antenna or air combining:
Systems are combined through the use of separate feeders for each technology. Generally less attractive due to the cost of the extra hardware and the higher tower rental charges. Sometimes not an option due to usage restrictions for the site.

3. Type 1 Combiners:

The type 1 combiner is one of the more simple devices for combining two base stations in a low loss manner. In this configuration, the base station 1 TX and RX main signals are routed to the first feeder and base station 2 TX and RX main are routed to the second feeder. Base station 1 RX diversity is connected to the second feeder and base station 2 RX diversity is fed from the 1st feeder. Note TX carriers are supplied by only one port from each BTS and this is sometimes a limitation in high capacity sites where they may appear on two ports of at least one BTS.

Type 1 combiners are not usually limited by the operator's bandwidth or frequency plan.

4. Type 2 Combiners:

Type 2 combiners enable the TX carriers to appear on two ports of one of the base stations. They are useful where maintaining existing capacity is important e.g. a metropolitan GSM cell-sites. They usually allow the BTS to supply 3-4dB more downlink power than the case where all carriers are transmitted from one antenna port of the BTS. This is sometimes a necessity to maintain path balance between uplink and downlink.

In type 2 configurations, we assume TX carriers appear at both ports of BTS 1 and TX carriers appear at only one port of BTS 2. Depending on the frequency plan and the desired combiner configuration, the TX carriers from BTS 1 may be combined to the same or different feeders. Base station 1 RX main is connected to the first feeder and base station 2 RX main is connected to the second feeder. Base station 1 RX diversity is connected to the second feeder and base station 2 RX diversity is fed from the 1st feeder.

Whilst type 2 combiners are suitable where the operator has both a continuous or split spectrum, they require careful attention to the details of the spectrum and guard bands available.

5. Overview of Active & Passive Combiners:

1. A passive combiner should usually be used in conjunction with a TMA and the combination is most attractive where a relatively long masthead feeder cable is in use e.g. at a rural cell-site using a tower. For receive sensitivity (noise figure) reasons, the TMA is generally sited near the antenna (at top of mast) & the combiner close to the base stations or node-Bs.

2. An active combiner can be viewed as the system equivalent of a TMA plus a passive combiner, i.e.: Active combiner = TMA + Passive combiner.

An active combiner is best suited to cell-sites where the feeder lengths (distance between BTS & antenna) is short, for example on an inner city roof-top. An active combiner will generally be more cost effective than the total cost of a TMA plus passive combiner.

6. Same Band Combining of GSM & UMTS:

There are a number of possible ways to combine UMTS900 and GSM900 at a cellular site. These are detailed in figure 3.10 of reference [1]. Same band combiner techniques & networks are only one method for bringing the two BTS signals together to the same feeder or antenna. Equally separate antennas (as per configuration 1, [1]) is preferred by some operators for reasons such as capacity, interference or flexibility. Further useful technical background is available in the ECC reports [2], [3]. Ovum Consulting [4] present a commercial and technical overview with a strong business case for UMTS in GSM900.

Most detailed technical reports suggest co-siting and the so-called sandwich arrangement” of GSM and UMTS (see Figure 1 below) to minimize interference and occupied spectrum. The same band combiners presented here are capable of using this arrangement or variations on it. The recommended frequency separation between the centre frequencies of the nearest GSM & UMTS carriers is reported to be in the range of 2.2-2.8 MHz. It is dependent on the RF performance of both the base station and mobiles in the presence of adjacent carriers.

Figure 1 Sandwich Arrangement (source ECC reports [2],[3])

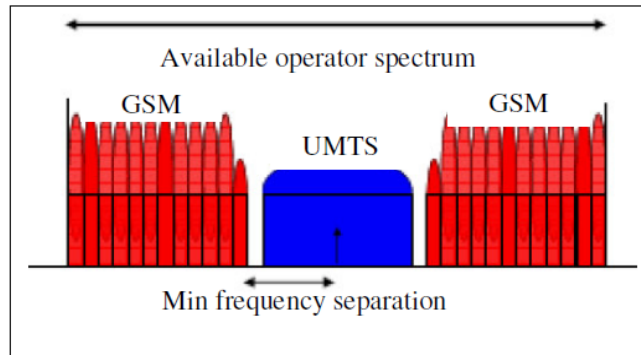

7. Active Type 1 Combiners:

This network combines both the transmit & receive signals from two base stations or node-Bs (using the same frequency bands) to the same antenna. Its block diagram (available on request from Triasx) is similar to a TMA (Tower Mounted Amplifier) with a splitters added in the RX paths. An insertion loss less than 1dB is demonstrated in the transmit path and the receive path has 12 dB gain (similar to a masthead amplifier) to overcome the noise figure degradation which would otherwise result from the output splitting loss. For minimum receive noise figure, it should to be fitted as close as possible to the antenna. However, for cost reasons, the feeder lengths below the device should also be minimized. Usually, these two factors mean that Active Type 1 combiners are best suited to roof-top applications. The internal architecture of the Active Type 1 means that transmit carriers can be carried by only one port of each base station & this causes limitations in some applications. If there is a requirement for transmit signals from both ports of one of the base stations e.g. GSM900, then a type 2 combiner could be more suitable. Note it is irrelevant whether the same modulation scheme is used in each base station in the type 1 configuration.

A typical application for using this type of combiner is:

- A GSM900 operator wishes to add UMTS900 for capacity reasons into existing spectrum. On metropolitan roof-top sites, the active type 1 combiner allows sharing of the masthead and enclosure equipment infrastructure in order to minimize capital & operational expenditure. Base station 1 (GSM900) has several TX carriers on one port & base station 2 (UMTS900) has TX carriers on one port. See [Figure 2](#) and [Figure 3](#) below for examples of possible spectrum and system block diagrams.

Figure 2 Typical Spectrum of Active Type 1 Combiner

Combining GSM & UMTS signals

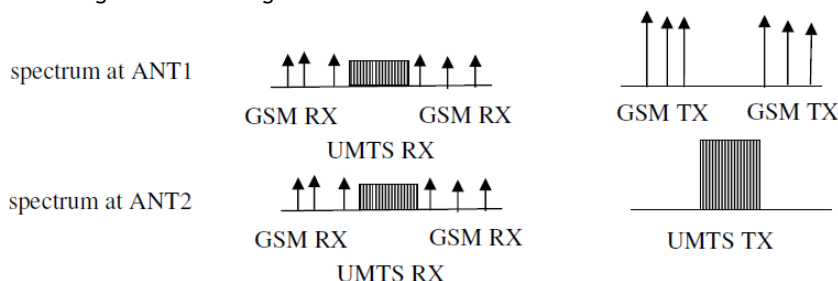
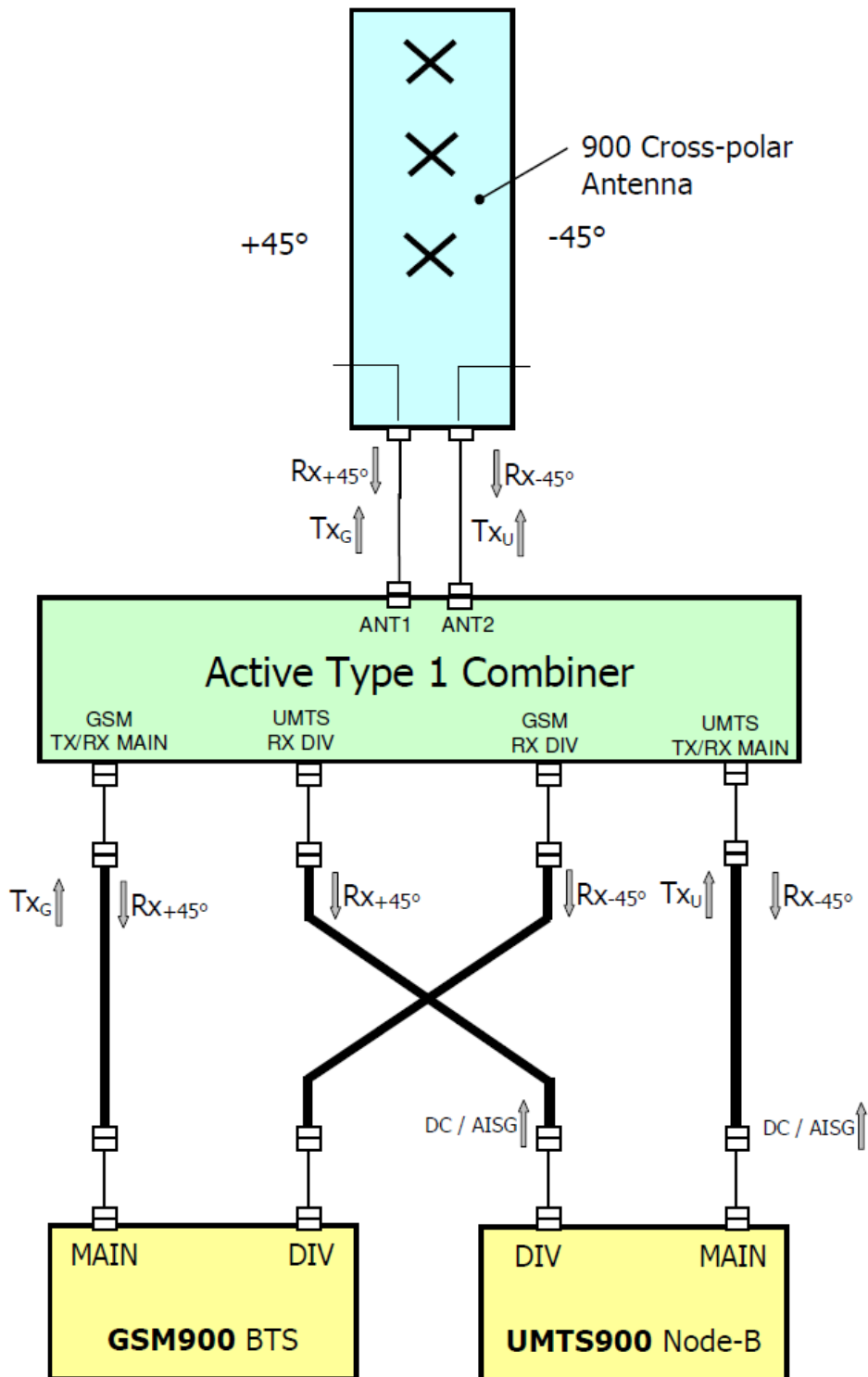

Figure 3 Active Type 1 Combiner - Typical System Block Diagram



8. Passive Type 1 Combiners:

This network also combines both the transmit & receive signals from two base stations or node-Bs (sharing the same frequency bands), to the same antenna. Its block diagram (available from Triax on request) is similar to the type 1 active network but with its amplifiers removed. An insertion loss less than 1dB in the transmit path and around 4.5dB in the receive path (due to the splitter loss) is demonstrated. For cost reasons, the Passive Type 1 combiner should be positioned as close to the base stations as possible, so the feeder lengths below the device are minimized. To minimize the receive system noise figure, a TMA (Tower Mounted Amplifier) should also be used and be fitted above the combiner unit, as close as possible to the antenna (see Figure 5). The combination of these two factors means that Passive Type 1 combiners are best suited to rural tower type installations. The internal architecture means that transmit carriers can be carried by only one port of each base station & this limits its usefulness in some applications e.g. high capacity GSM sites. If there is a requirement for transmit signals from both ports of one of the base stations (usually GSM900), then a type 2 combiner could be more suitable (see later). It is irrelevant whether the same modulation scheme is used on each base station.

A typical application for using this type of combiner is:

- A GSM900 operator wishes to add UMTS900 for capacity reasons into existing spectrum. At rural sites using towers of 10-40m in height, in conjunction with a TMA, the Passive Type 1 combiner allows sharing of the masthead and enclosure equipment infrastructure. Base station 1 (GSM900) has 2x TX carriers on one port & base station 2 (UMTS900) has TX carriers one port. The resulting spectrum and system block diagrams are shown in [Figure 4](#) and [Figure 5](#).

Figure 4 Typical Spectrum of Passive Type 1 Combiner

Same band combining of GSM & UMTS.

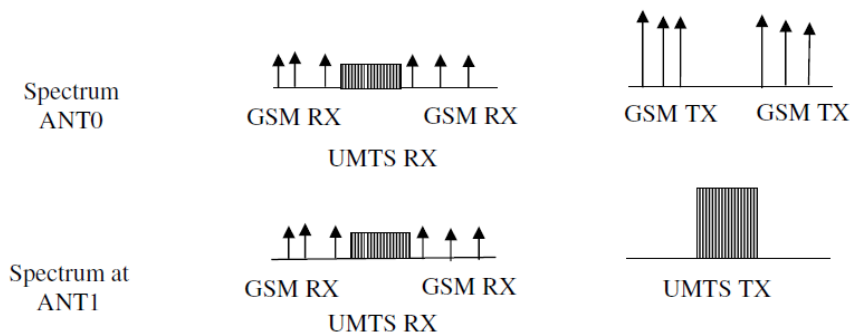
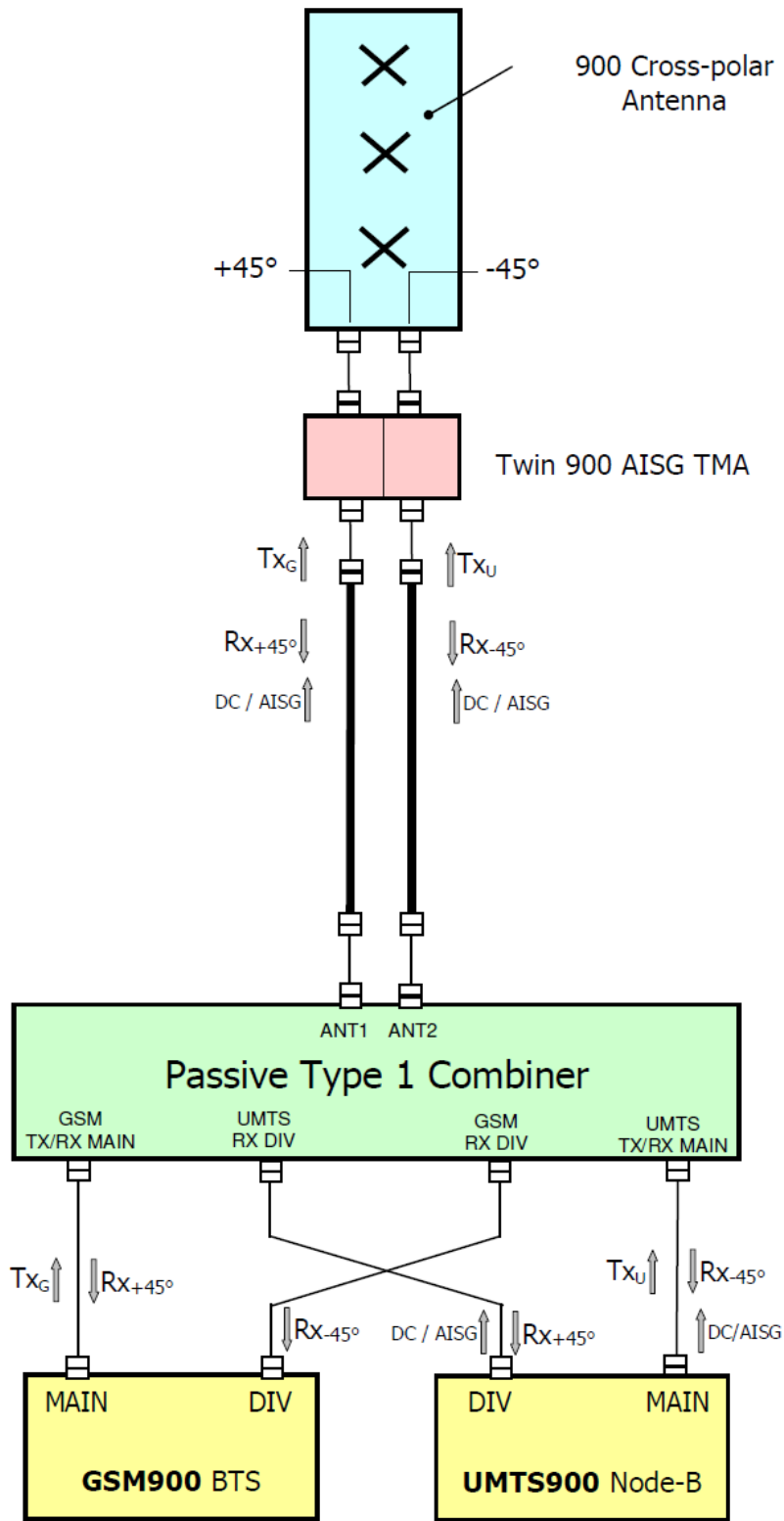

Figure 5 Passive Type 1 Combiner - System Block Diagram



9. Active Type 2 Combiners:

This active network combines signals from two base stations or node-Bs (using the same frequency bands) to the same antenna. A typical system block diagram is included below in [Figure 7](#). The module block diagram is available on request from Triasx. A key feature is that one of the base stations can transmit on both ports (where a type 1 combiner allows only one), which is often required at high capacity sites. It is also irrelevant whether the same modulation scheme is used on each base station. It has an overall RX gain in the region of 12dB and an insertion loss is less than 1dB in the transmit path. For cost reasons, the Active Type 2 combiner should be positioned as close to the base stations as possible, so the feeder lengths below the device are minimized. To minimize the receive system noise figure, the device should also be fitted as close as possible to the antenna. Active Type 2 combiners are best suited to roof-top type installations in metropolitan areas. The internal architecture of the Type 2 combiner causes limitations in certain applications e.g. where limited spectrum is available. In these cases, a type 1 combiner may be more suitable.

A typical application for this type of combiner is:

- A GSM900 operator wishes to add UMTS900 for capacity reasons into existing spectrum. At metropolitan roof-top sites, an Active Type 2 combiner allows sharing of the masthead and enclosure equipment infrastructure in order to minimize capex & opex. Base station 1 (GSM900) has several TX carriers on each port and base station 2 (UMTS900) has TX carriers on only one port. The resulting spectrum and system block diagrams are shown in [Figure 6](#) and [Figure 7](#).

Figure 6 Typical Spectrum of Active Type 2 Combiner (at antenna ports)

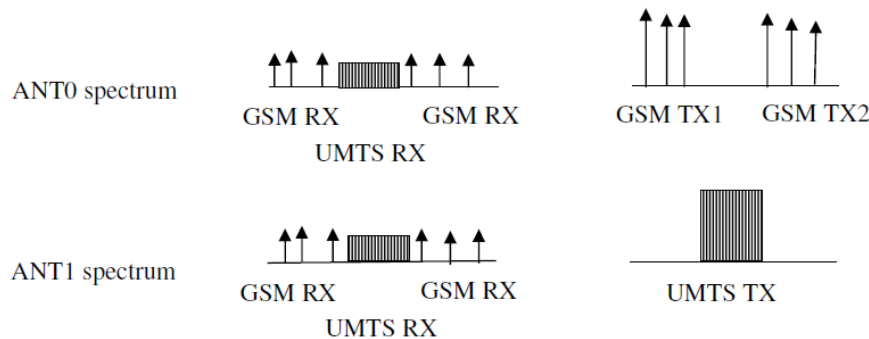
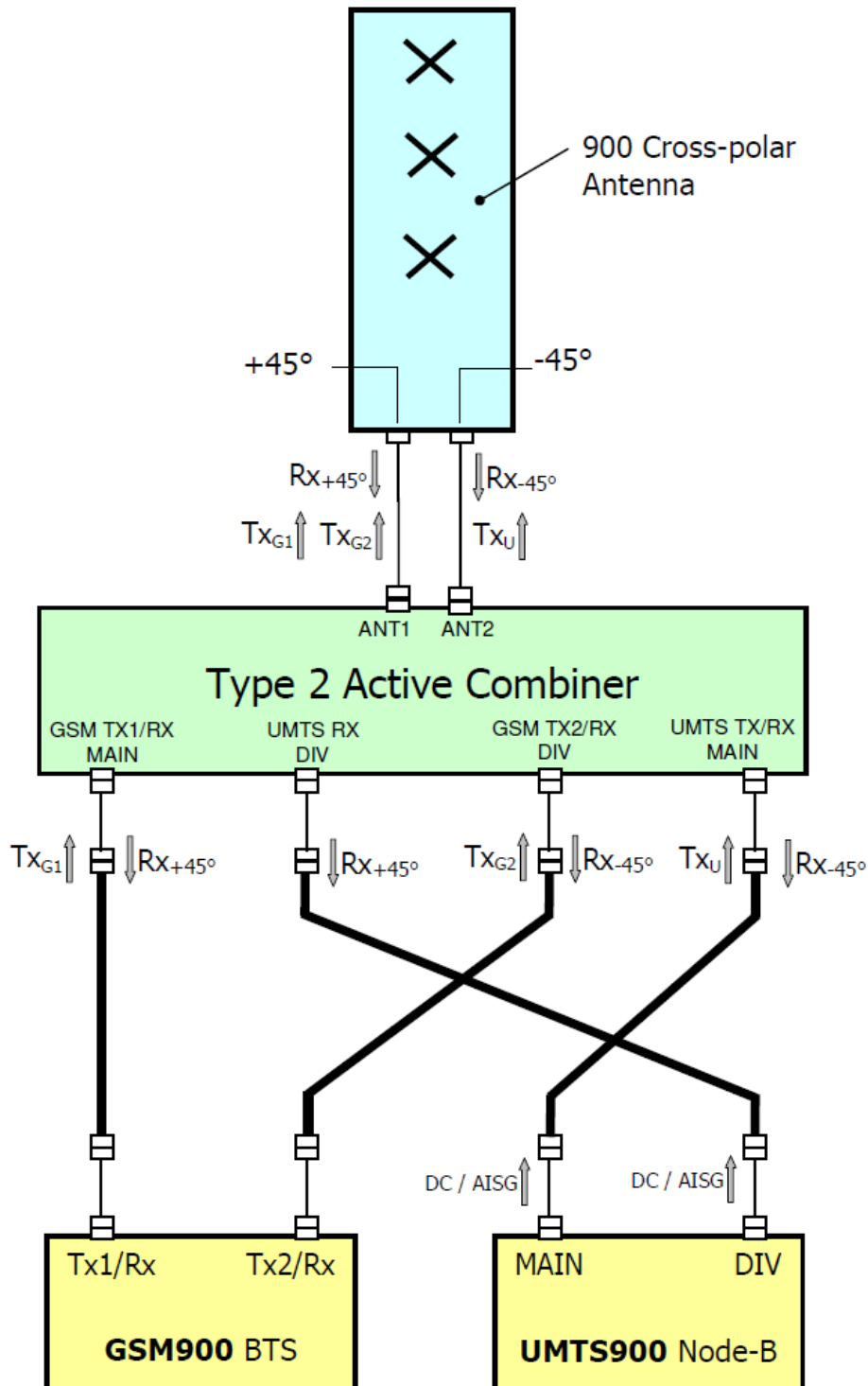

Figure 7 Active Type 2 Typical System Block Diagram

Note TX carriers may appear on the other feeder in some configurations.



10. Passive Type 2 Combiners:

This hardware combines signals from two base stations or node-Bs (using the same frequency bands) to the same antenna. A typical system block diagram is included below in [Figure 9](#). A key feature is that one of the base stations can transmit on both ports (where a type 1 combiner allows only one), which is often required at high capacity sites. It is also irrelevant whether the same modulation scheme is used on each base station. The module block diagram is available on request from Triasx. Its insertion loss is less than 1dB in all transmit paths and 4.5dB in the receive path (due to splitter loss). Normally a TMA is used above the unit & mounted as close to the antennas as possible. For cost reasons, the feeder lengths below the device should be minimized by mounting it close to the base stations. Usually, these two factors mean that the Passive Type 2 combiner is best suited to rural, bottom of the tower situations. The internal architecture of the Type 2 combiner has limitations, e.g. it is not suited to applications where limited spectrum is available. In these cases, a Type 1 combiner may be more suitable.

An example application using this type of combiner is:

- A GSM900 operator wishes to add UMTS900 for capacity reasons into its existing spectrum. At rural sites using feeder lengths of 20 to 30 meters, the Passive Type 2 combiner (along with a masthead mounted TMA) allows sharing of the masthead and enclosure equipment infrastructure. Base station 1 (GSM900) has 2x TX carriers on each port and base station 2 (UMTS900) has TX carriers on only one port. The resulting spectrum and system block diagrams are shown in [Figure 8](#) and [Figure 9](#).

Figure 8 Typical Spectrum of Passive Type 2 combiner (at the antenna port)

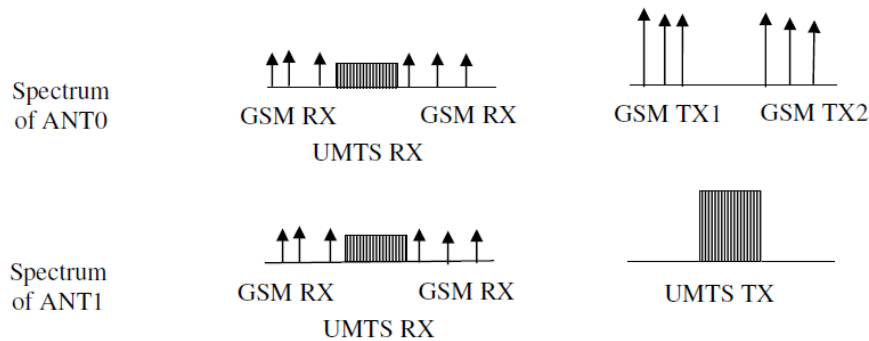
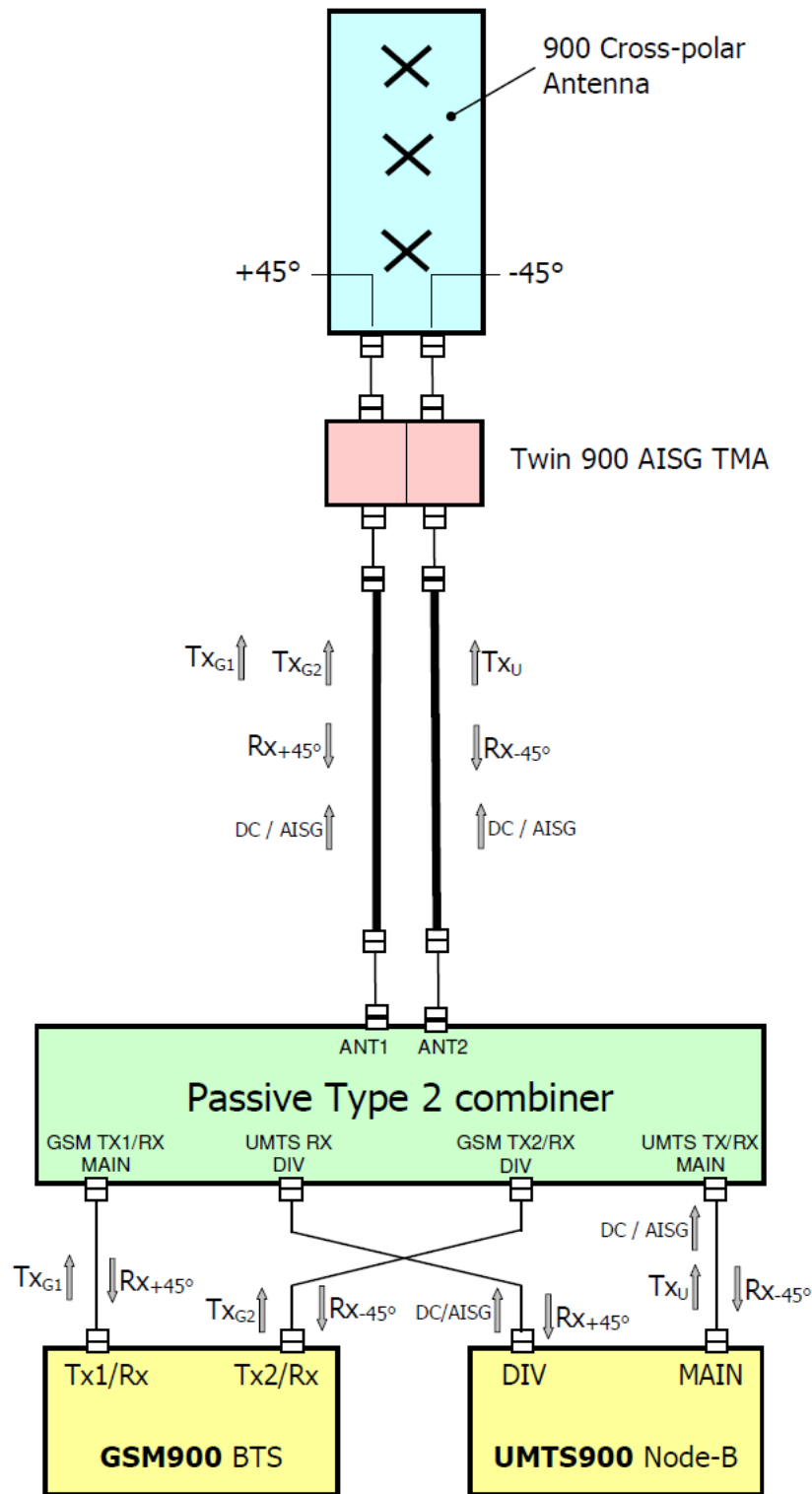

Figure 9 Passive Type 2 Combiner - Typical System Block Diagram

Note different TX carrier arrangements may be used in some configurations.



11. Passive Type 3 Combiners:

A type 3 combiner differs from types 1 and 2 in that it allows transmit carriers to be placed on two ports of the each base station. A typical system block diagram for this unit is included below in **Figure 11** and shows a masthead amplifier fitted near the antenna (common for frequency bands at 1800 MHz or above). The module block diagram is available on request from Triasx. A typical passive type 3 combiner would expect an insertion loss of less than 1dB in each pass band. To minimize feeder lengths (and their cost) below the device it is best to locate it close to the two base stations, usually within their enclosure or nearby in the case of radio heads. A typical spectrum is included below in **Figure 10**. Note the performance is highly dependent on the filter structure used in the combiner and a minimum guard-band of 1 to 2 MHz is usually required between the pass bands used by the two base stations.

Some examples using this type of combiner include:

- two UMTS2100 operators wish to share masthead and enclosure equipment infrastructure in order to minimize capital & operation expenditure. The combiner is placed inside the base station enclosure.
- A GSM1800 operator would like to add capacity to existing sites without purchasing extra masthead equipment (feeder cables & antenna) and minimizing loss of transmit power & receive sensitivity.

Figure 10 Typical Spectrum of Passive Type 3 Combiner (at both antenna ports)

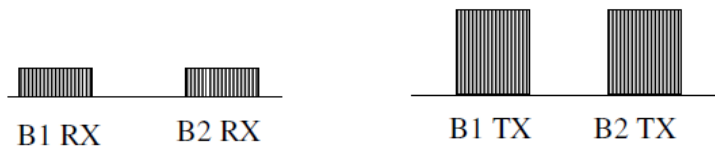
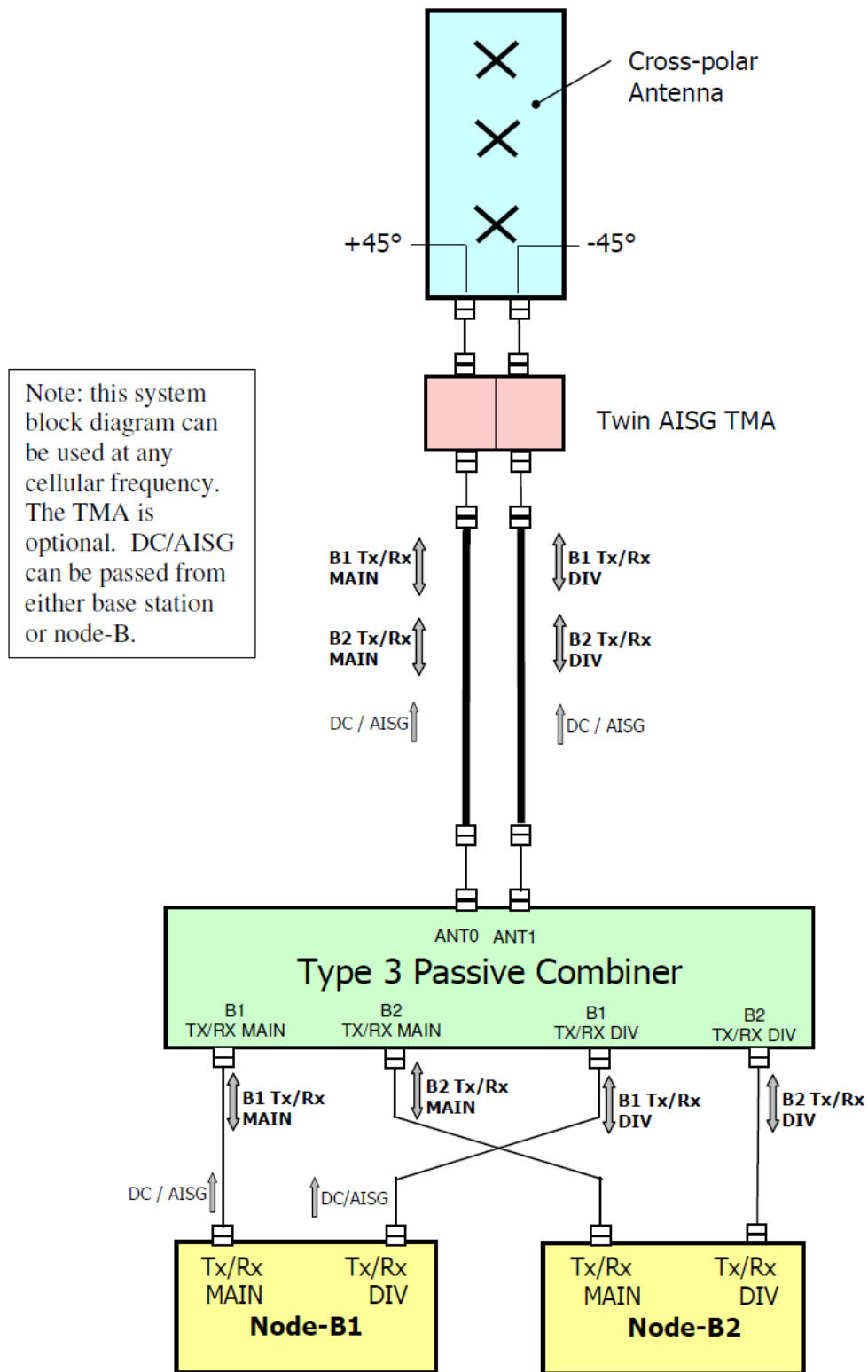

Figure 11 Passive Type 3 Combiner System Block Diagram



12. References:

1. Qualcomm ESG, Engineering Services Group, UMTS900 Overview & Deployment Guidelines, November 2006, 80-W1044-1 Rev A
http://www.qualcomm.com/esg/media/pdf/UMTS900_Overview_Deployment_Guidelines.pdf,
Accessed 4 October 2007
2. Electronic Communications Committee (ECC) within the European Conference of Postal and Telecommunications Administrations (CEPT), ECC Report 82, COMPATIBILITY STUDY FOR UMTS OPERATING WITHIN THE GSM 900 AND GSM 1800 FREQUENCY BANDS, Roskilde, May 2006
<http://www.ero.dk/documentation/docs/doc98/official/pdf/ECCREP082.pdf>, Accessed 4 October 2007
3. Electronic Communications Committee (ECC) within the European Conference of Postal and Telecommunications Administrations (CEPT), ECC Report 96, COMPATIBILITY BETWEEN UMTS 900/1800 AND SYSTEMS OPERATING IN ADJACENT BANDS, Krakow, March 2007
<http://www.ero.dk/documentation/docs/doc98/official/pdf/ECCREP096.pdf>, Accessed 4 October 2007.
4. Ovum consulting report, Market Study for UMTS900, A report to GSMA, February 2007, Project Number CLW28, Version - V1.1
http://www.gsmworld.com/documents/umts900_full_report.pdf, Accessed 4 October 2007, 114 pages.



Americas
+1.303.768.8080

Asia Pacific, Africa
+61.(0).7.3907.1200

China
+86.21.6084.2200

Europe, Middle East, India
+44.(0).1383.410386

info@kaelus.com